

# Interia

Creating Work[ing] Spaces



## Jute

Sit - Stand Workstation

8 - 10 Week Lead Time

# Jute

The Jute Workstation range features award-winning highly engineered design, industry leading environmental certification, and exceptional functionality, offering a sustainable solution for modern hybrid workplaces.

## Features

- Rectangular and Round Leg Profile Options
- Linak Motors and Controller
- Height Range:
  - Square: 595–1245MM
  - Round: 605–1255MM
- Maximum Load Capacity : 150kgs
- Speed: 600/700MM
- Low Noise Level: <50 dB (empty load)
- Sliding worktop for convenient access to power
- Clean and tidy cable management options
- Choice of any Laminex or Polytec commercial ranges for desktop colours. Other colours available on request.
- Australian Made, PEFC™ Certified Desktop
- SEDEX® Certified Desktop Manufacturer who partners with Carbon Neutral by offsetting emissions
- Environmental Product Declaration (EPD) and Greenguard Certification

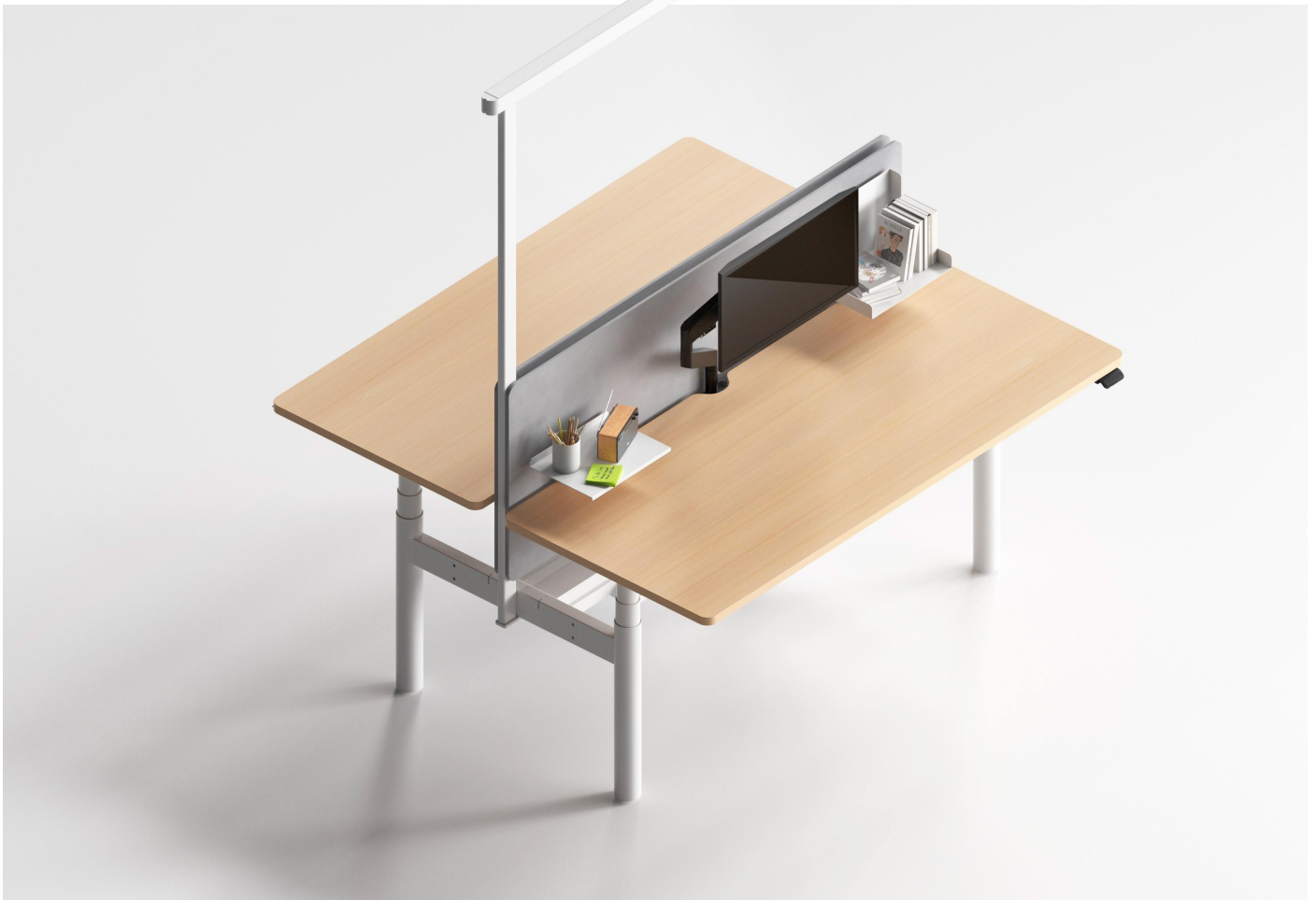

## Sample Configurations

- 180 Degree Single
- 180 Degree B2B with bridge cable duct
- 120 Degree Pod
- 90 Degree Corner workstation



## Desktop Type



Standard

Scollop

Cut Outs

## Desktop Colour Options

Full Laminex and Polytec range available

**Laminex<sup>®</sup>**  
**polytec**



Polar White

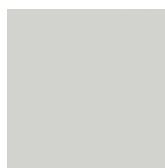

Oyster Grey

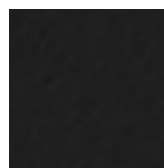

Absolute Matte  
Black



NEW - Laminex  
Spotted Gum



NEW - Polytec  
Australian Native

## Standard Powdercoat Colour Options



## Certifications



## Table Top

Jute's unique design eliminated the need for cable grommets on the desk, increasing the usable surface area providing more convenient access to power, a larger workspace and a more pleasant experience.



Jute offers a 150mm tabletop sliding stroke, increasing the tabletop area without changing its size, while maintaining reliable stability.

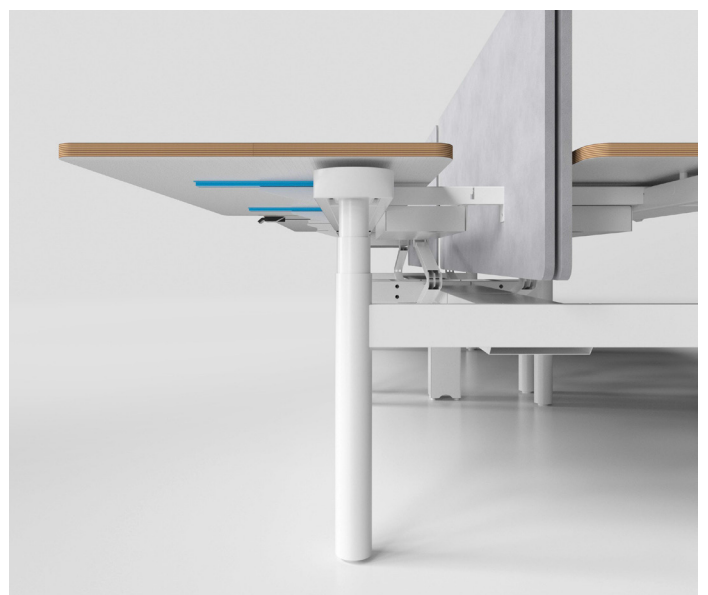
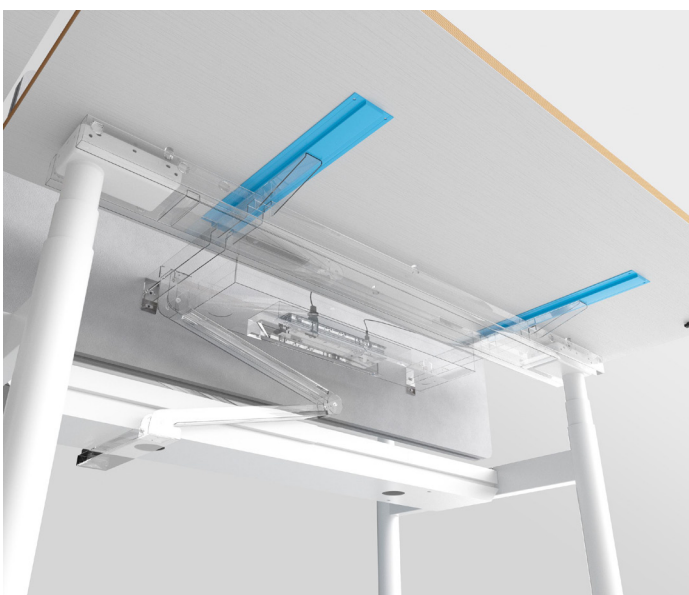



## Cable Management

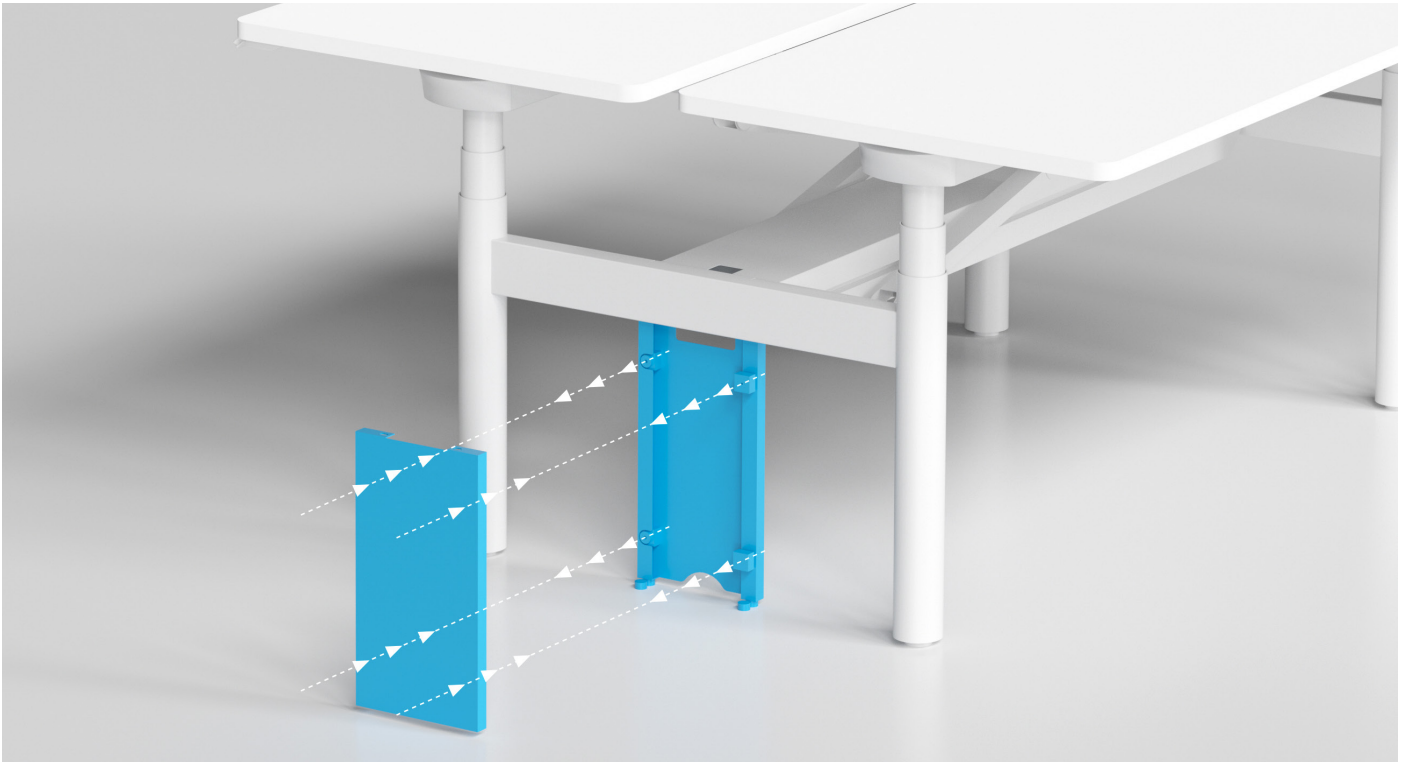

Made from powder-coated metal, featuring a magnetic closure for easy assembly and disassembly. Available in various table configurations with corresponding sizes.

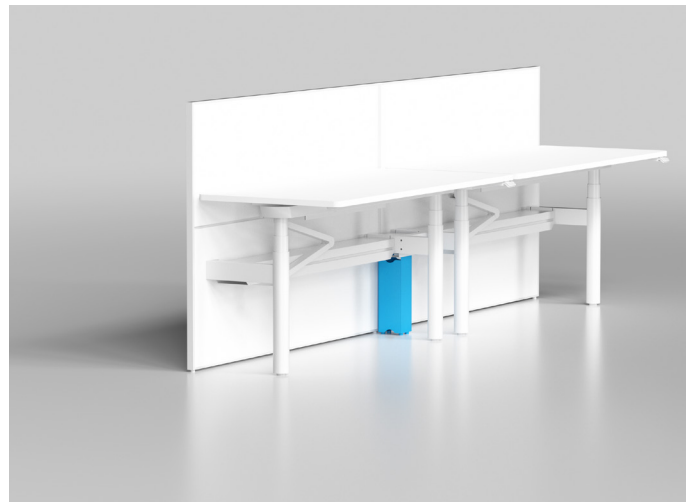

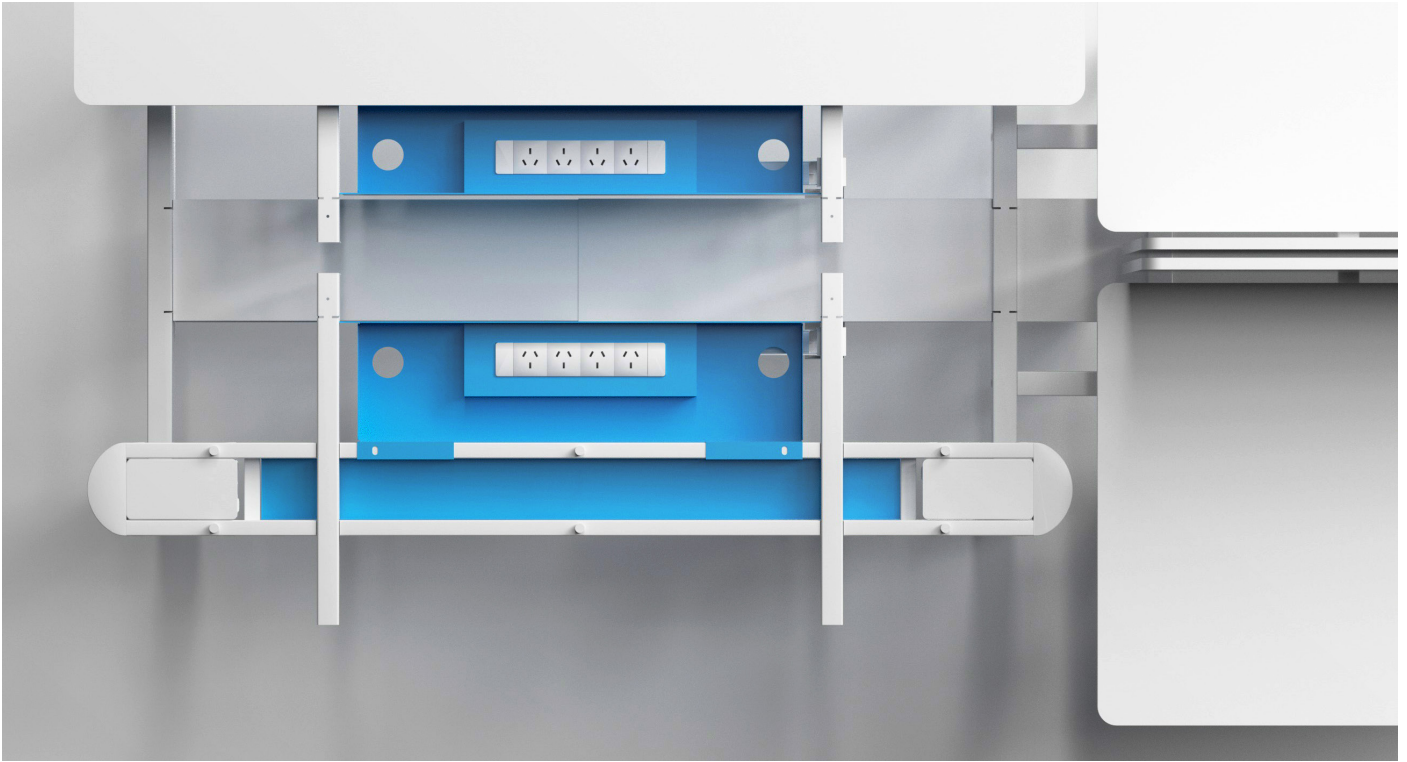

The under-desk cable tray is a modular solution designed to be fixed onto the frame rather than the traditional method of attaching it to the worktop. It provides a dedicated space for integrated power sockets and control boxes. This design makes installation and maintenance easy.

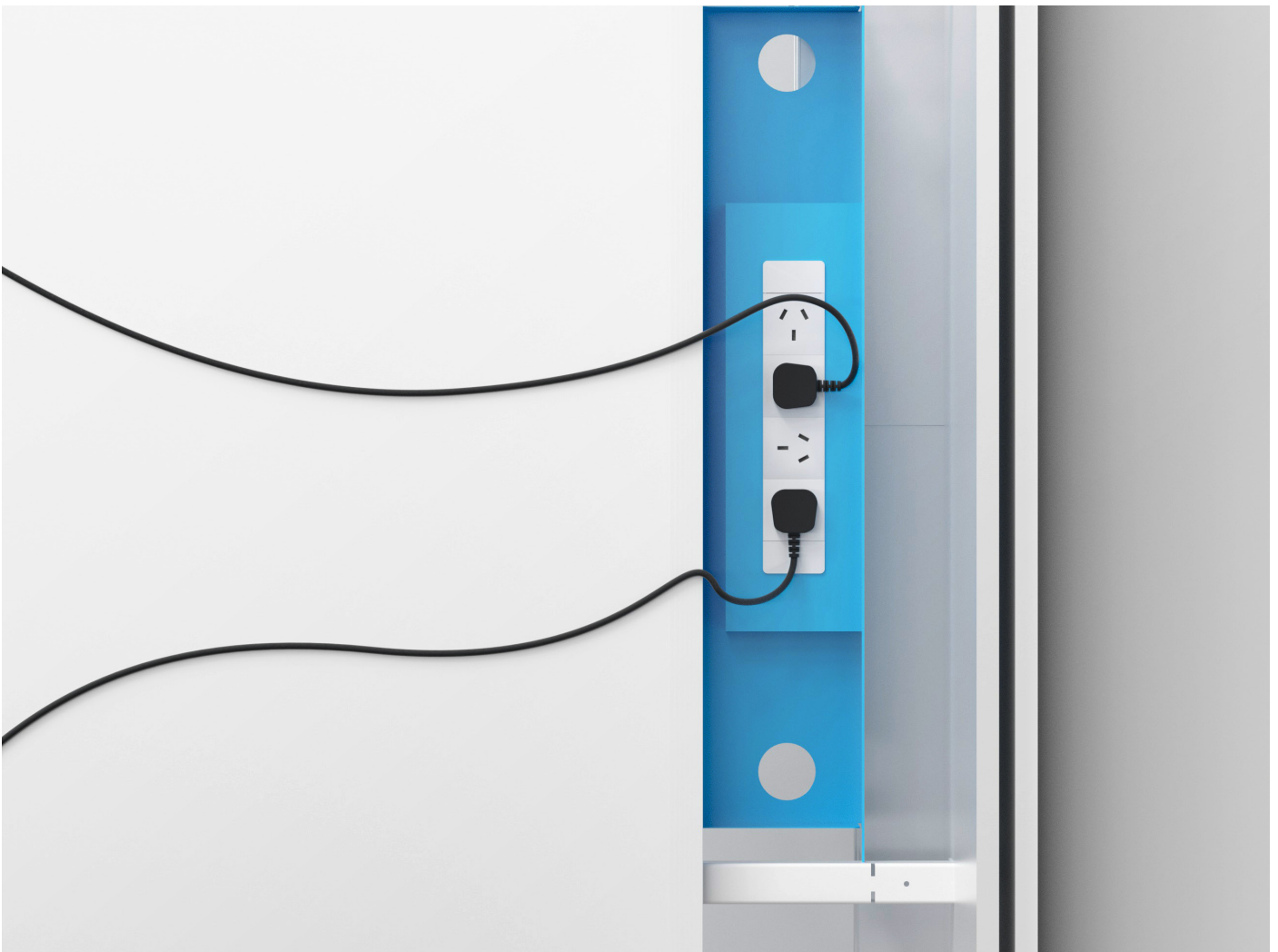

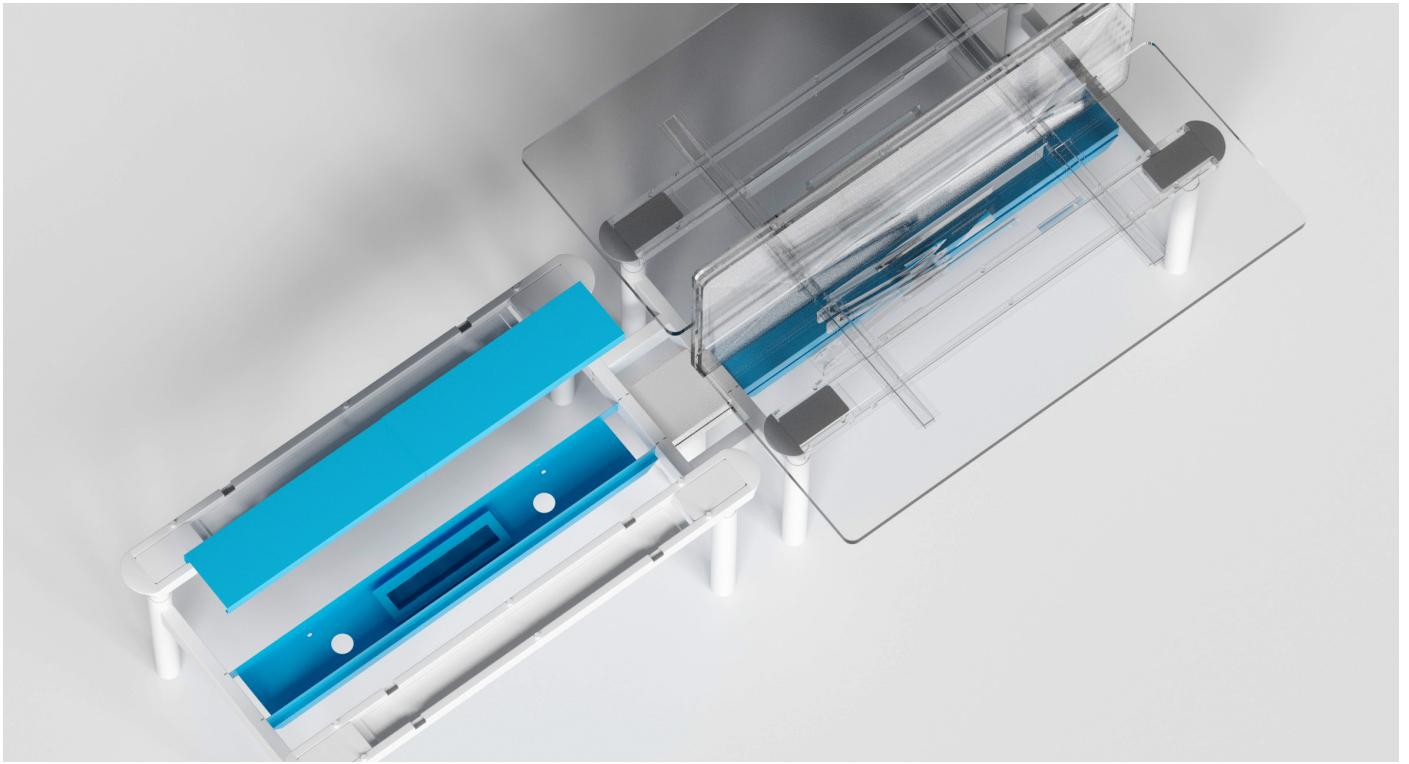

Hanging cable tray for convenient access, featuring an angled bottom for easier cable entry. The removable top provides extra space and helps prevent cable overlap.

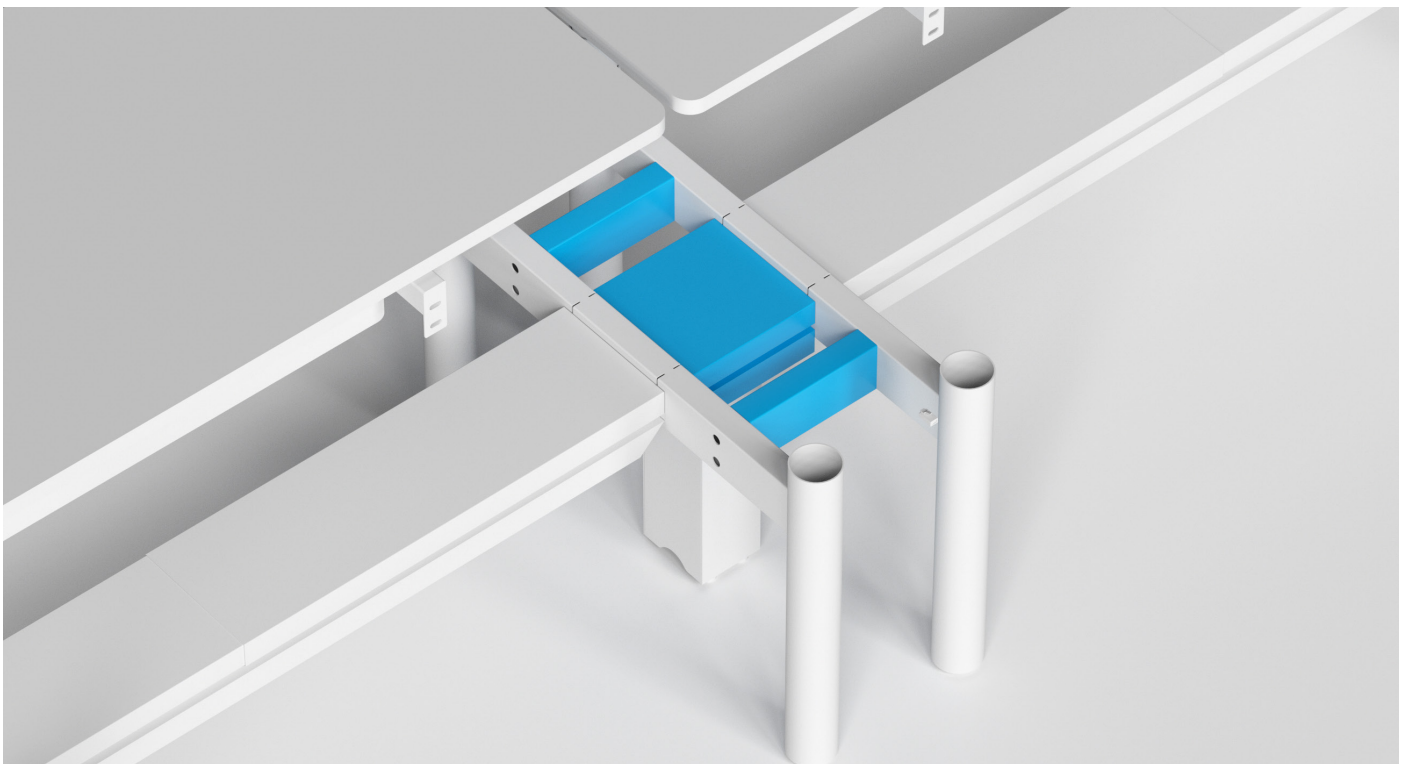

Enclosed cable tray positioned between back-to-back workstations for enhanced safety.



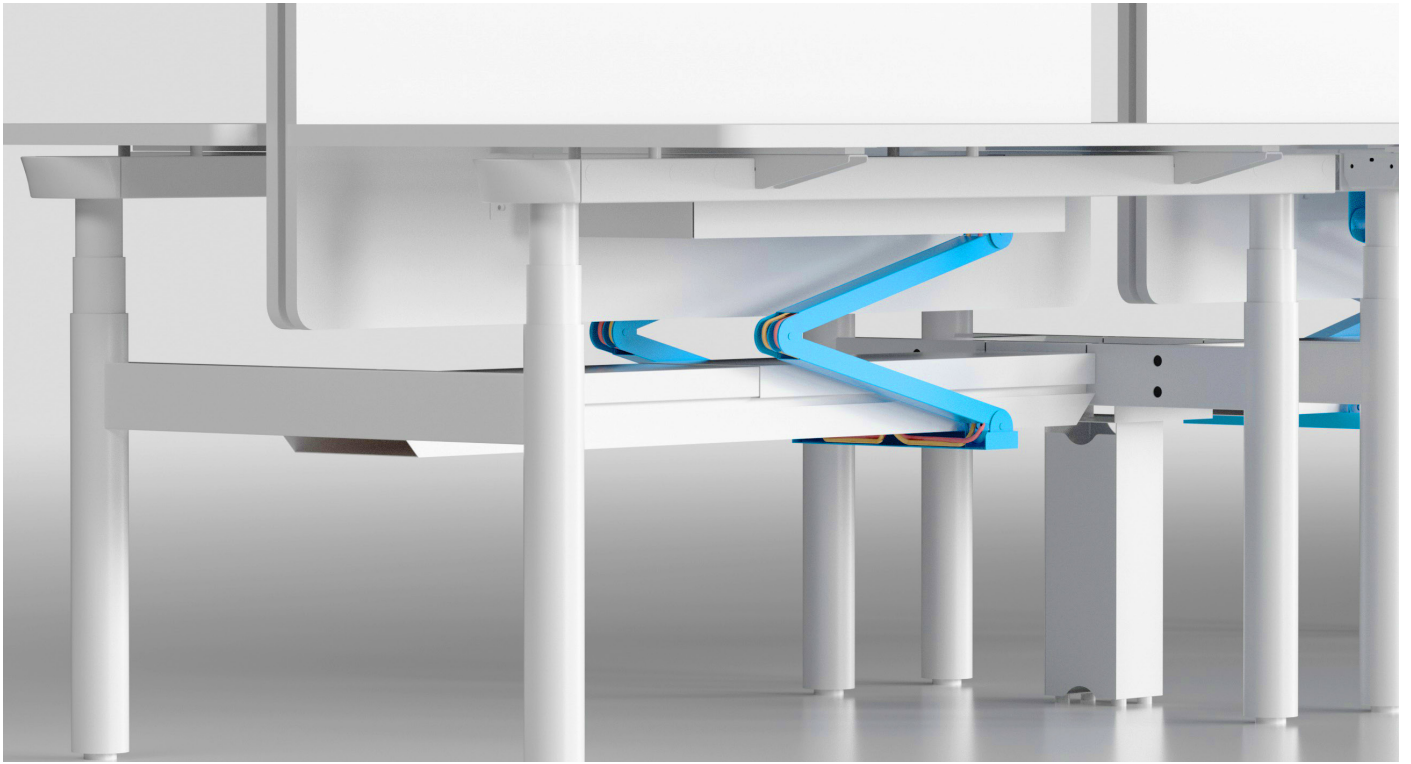

Highly engineered design for easy installation and minimal noise during lifting. The bionic design enhances wire management efficiency.

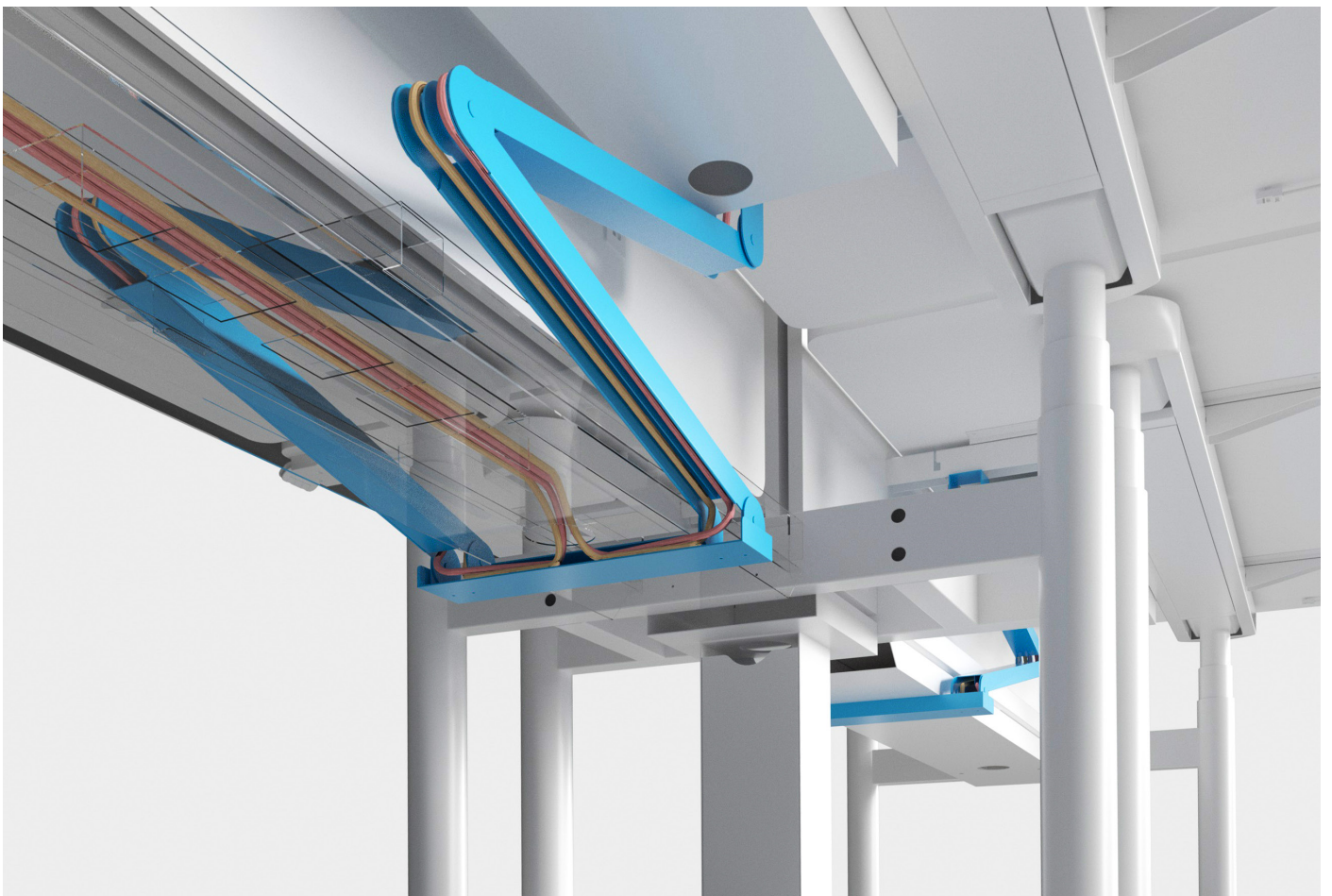

A movable cover allows for easy wire management and maintenance.



## Accessories

This workspace is designed to enhance efficiency, providing ample room for seamless multitasking and helping to keep tasks organized. With the added flexibility of incorporating a CPU holder, monitor arm, or various other accessories, it promotes a more ergonomic and comfortable working posture.

### Lighting



- Dimmable 4000k lighting
- Concealed input outlets

### Bookstand



- Functional integrated
- Different sizes available

### Monitor Arm



- 360° rotation
- Single/dual screen options

### Decorative Side Leg

Create the privacy between the workstations by using the magnetic side panel in metal or coordinated laminate finish.

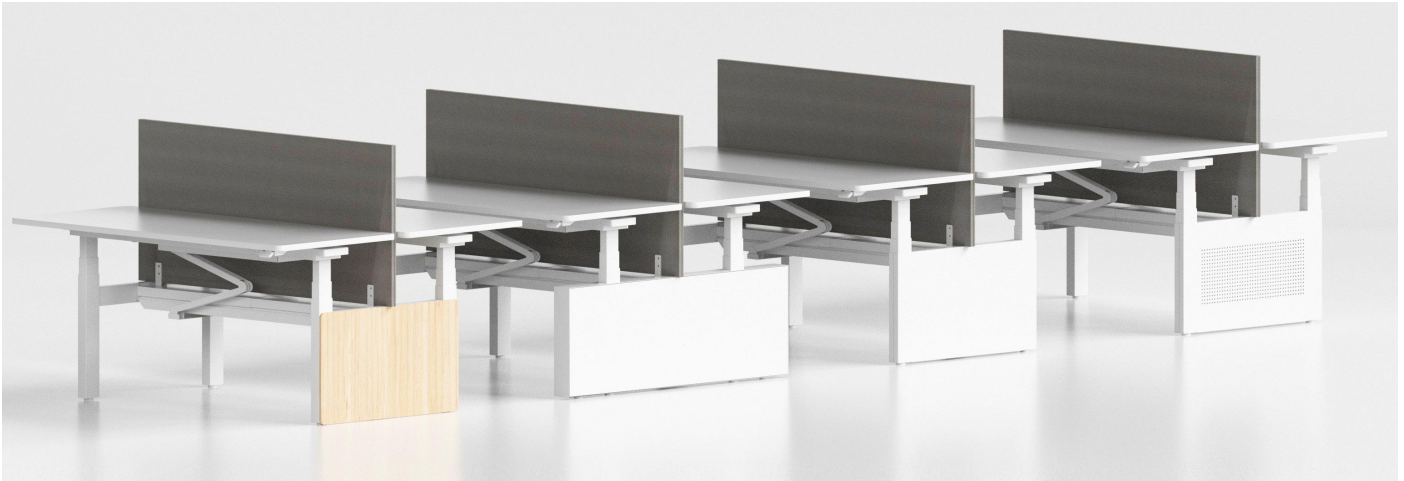

### CPU Holder

The ventilation hole serves a dual purpose—it helps cool the CPU during operation while also acting as a design feature for hanging accessories.

For those using a laptop, there is an option to add a hanging drawer, available in either wood or metal finishes.



# Specifications

## Single Free Standing

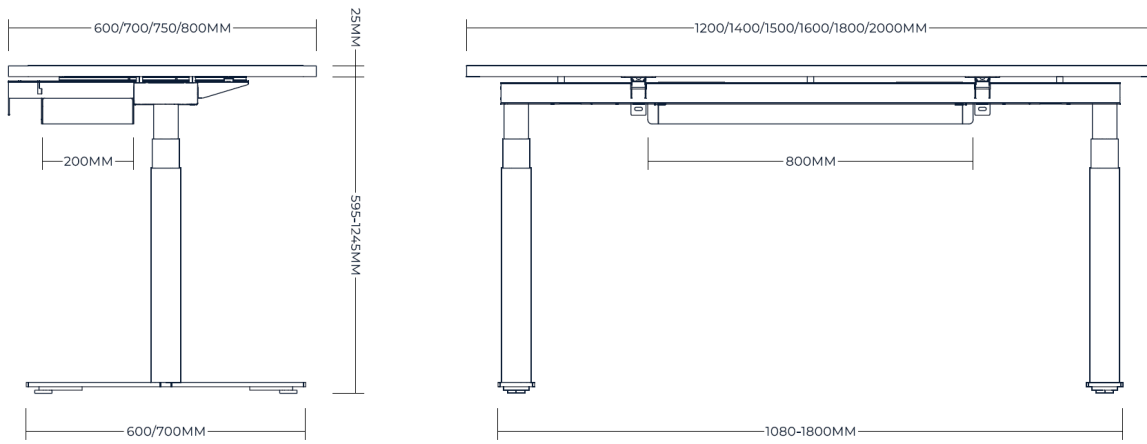

## Bench & B2B Workstation

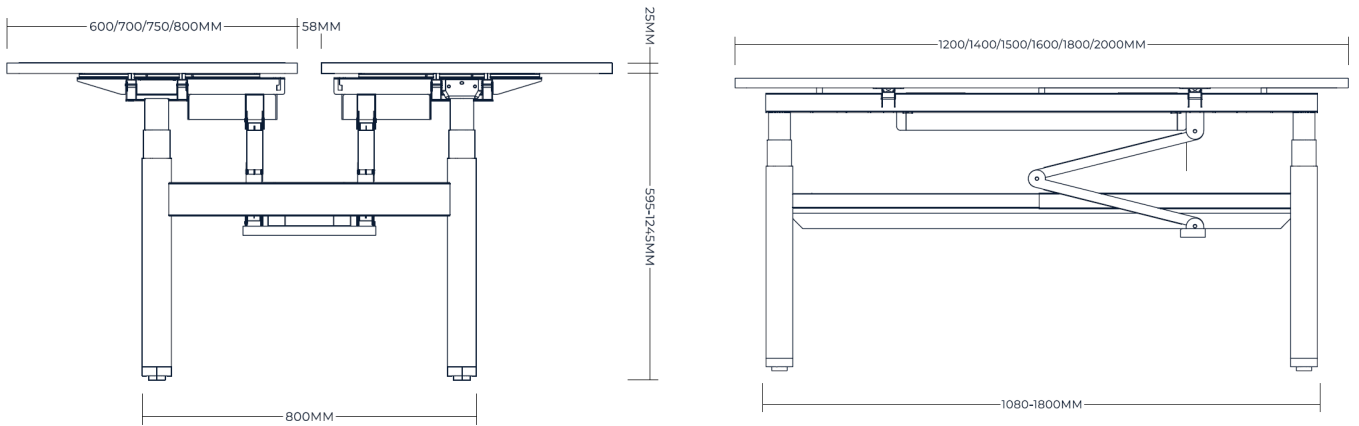

## 3 - Way Workstation

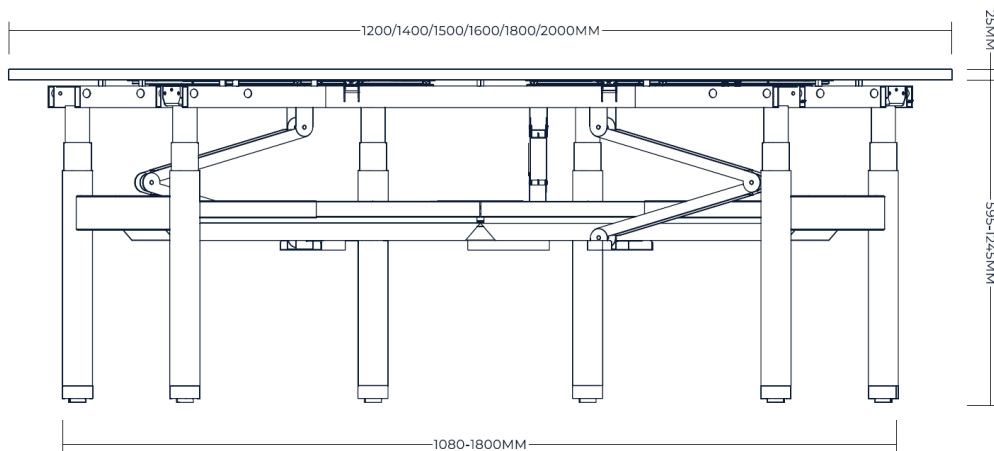



# CONTACT

1300 784 814  
[sales@interia.com.au](mailto:sales@interia.com.au)

Showroom  
Old Cloisters Building  
200 St. Georges Terrace,  
Perth WA 6000

Head Office  
21 - 25 Chisholm Crescent,  
Kewdale WA 6105

Connect with us  
on social media!